

# Bias Resistor Transistors (BRT)

PNP, 50 V, 100 mA

## NSBAMXW Series

The series of digital transistors is designed to replace a single device and its external resistor bias network. The Bias Resistor Transistor contains a single transistor with a monolithic bias network consisting of two resistors: a series base resistor and a base-emitter resistor. The BRT eliminates these individual components by integrating them into a single device. The use of a BRT can reduce both system cost and board space. They are housed in the DFN1010-3 package offering superior thermal performance. The transistor is ideal for surface mount applications where board space and reliability are at a premium.

### Features

- Built in Bias Resistors
- Complimentary NPN Types Available
- XDFNW3 Package Offers Low Seated Height – 0.44 mm Max
- Wettable Flank Package for Optimal Automated Optical Inspection (AOI)
- NSV Prefix for Automotive and Other Applications Requiring Unique Site and Control Change Requirements; AEC-Q101 Qualified and PPAP Capable
- These Devices are Pb-Free, Halogen Free/BFR Free and are RoHS Compliant

### Applications

- Digital Switching
- Controlling IC Input

### MAXIMUM RATINGS (T<sub>A</sub> = 25°C)

Rating	Symbol	Min	Max	Unit
Collector – Emitter Voltage	V <sub>CEO</sub>		-50	V
Collector – Base Voltage	V <sub>CBO</sub>		-50	V
Input Voltage	V <sub>I</sub>			V
NSBA114EMXWTBG		-40	+10	
NSBA124EMXWTBG		-40	+10	
NSBA143EMXWTBG		-30	+10	
NSBA144EMXWTBG		-40	+10	
NSBA123YMXWTBG		-5	+12	
Collector Current	I <sub>C</sub>		100	mA
Electrostatic Discharge (HBM)	ESD	Class 1B		

Stresses exceeding those listed in the Maximum Ratings table may damage the device. If any of these limits are exceeded, device functionality should not be assumed, damage may occur and reliability may be affected.

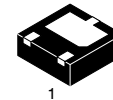

XDFNW3  
CASE 521AC

### PIN CONNECTIONS

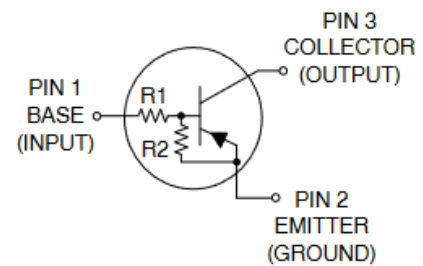

### MARKING DIAGRAM

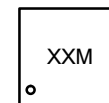

XX = Specific Device Code  
M = Date Code

### ORDERING INFORMATION

See detailed ordering, marking and shipping information on page 2 of this data sheet.

## NSBAMXW Series

### THERMAL CHARACTERISTICS

Characteristic	Symbol	Max	Unit
Total Power Dissipation @ $T_A = 25^\circ\text{C}$ (Note 1)	$P_D$	450	mW
Thermal Resistance, Junction-to-Ambient (Note 1)	$R_{\theta JA}$	145	$^\circ\text{C}/\text{W}$
Junction and Storage Temperature Range	$T_J, T_{stg}$	-65 to +150	$^\circ\text{C}$

1. Per JE5D51-7 with standard PCB footprint and 2 oz. Cu.

### ORDERING INFORMATION

Device	Device-Automotive*	R1	R2	Part Marking	Package†	Shipping
NSBA114EMXWTBG	NSVBA114EMXWTBG	10	10	4X	XDFNW3 (Pb-Free)	3000 / Tape & Reel
NSBA124EMXWTBG	NSVBA124EMXWTBG	22	22	4Y		
NSBA143EMXWTBG	NSVBA143EMXWTBG	4.7	4.7	4V		
NSBA144EMXWTBG	NSVBA144EMXWTBG	47	47	4Z		
NSBA123YMXWTBG	NSVBA123YMXWTBG	2.2	10	4W		

†For information on tape and reel specifications, including part orientation and tape sizes, please refer to our Tape and Reel Packaging Specifications Brochure, BRD8011/D.

\*S and NSV Prefix for Automotive and Other Applications Requiring Unique Site and Control Change Requirements; AEC-Q101 Qualified and PPAP Capable.

## NSBAMXW Series

### ELECTRICAL CHARACTERISTICS ( $T_A = 25^\circ\text{C}$ unless otherwise noted)

Characteristic		Symbol	Min	Typ	Max	Unit
Collector-Base Cutoff Current ( $V_{CB} = -50\text{ V}$ , $I_E = 0$ )		$I_{CBO}$	-	-	-100	nA
Collector-Emitter Cutoff Current ( $V_{CE} = -50\text{ V}$ , $I_B = 0$ )		$I_{CEO}$	-	-	-500	nA
Emitter-Base Cutoff Current ( $V_{EB} = -5\text{ V}$ , $I_C = 0$ )	NSBA114E	$I_{EBO}$	-	-	-0.5	mA
	NSBA124E		-	-	-0.2	
	NSBA143E		-	-	-1.5	
	NSBA144E		-	-	-0.13	
	NSBA123Y		-	-	-0.7	
DC Current Gain ( $V_{CE} = -10.0\text{ V}$ , $I_C = -5\text{ mA}$ )	NSBA114E	$h_{FE}$	35	-	-	
	NSBA124E		60	-	-	
	NSBA143E		15	-	-	
	NSBA144E		80	-	-	
	NSBA123Y		35	-	-	
Collector-Emitter Saturation Voltage ( $I_C = -10\text{ mA}$ , $I_B = -0.3\text{ mA}$ )		$V_{CE(sat)}$	-	-	-0.25	V
Input Voltage (off) ( $V_{CE} = -5.0\text{ V}$ , $I_C = -100\text{ }\mu\text{A}$ )	NSBA114E	$V_{I(off)}$	-	-1.2	-0.8	V
	NSBA124E		-	-1.2	-0.8	
	NSBA143E		-	-1.2	-0.5	
	NSBA144E		-	-1.2	-0.8	
	NSBA123Y		-	-0.75	-0.3	
Input Voltage (on)	NSBA114E ( $V_{CE} = -0.3\text{ V}$ , $I_C = -10\text{ mA}$ )	$V_{I(on)}$	-2.5	-1.8	-	V
	NSBA124E ( $V_{CE} = -0.3\text{ V}$ , $I_C = -5\text{ mA}$ )		-2.5	-1.7	-	
	NSBA143E ( $V_{CE} = -0.3\text{ V}$ , $I_C = -20\text{ mA}$ )		-3	-2.4	-	
	NSBA144E ( $V_{CE} = -0.3\text{ V}$ , $I_C = -5\text{ mA}$ )		-3	-1.6	-	
	NSBA123Y ( $V_{CE} = -0.3\text{ V}$ , $I_C = -20\text{ mA}$ )		-2.5	-1.15	-	
Output Voltage (on) ( $V_{CC} = 5.0\text{ V}$ , $V_B = 3.5\text{ V}$ , $R_L = 1.0\text{ k}\Omega$ )		$V_{OL}$	-	-	0.2	V
Output Voltage (off) ( $V_{CC} = 5.0\text{ V}$ , $V_B = 0.5\text{ V}$ , $R_L = 1.0\text{ k}\Omega$ )		$V_{OH}$	4.9	-	-	V
Bias Resistor (R1)	NSBA114E	R1	7	10	13	k $\Omega$
	NSBA124E		15.4	22	28.6	
	NSBA143E		3.3	4.7	6.1	
	NSBA144E		32.9	47	61.1	
	NSBA123Y		1.54	2.2	2.86	
Resistor Ratio	NSBA114E	R1/R2	0.8	1	1.2	
	NSBA124E		0.8	1	1.2	
	NSBA143E		0.8	1	1.2	
	NSBA144E		0.8	1	1.2	
	NSBA123Y		0.18	0.22	0.27	

Product parametric performance is indicated in the Electrical Characteristics for the listed test conditions, unless otherwise noted. Product performance may not be indicated by the Electrical Characteristics if operated under different conditions.

# NSBAMXW Series

## TYPICAL CHARACTERISTICS (Ref NSBA124E)

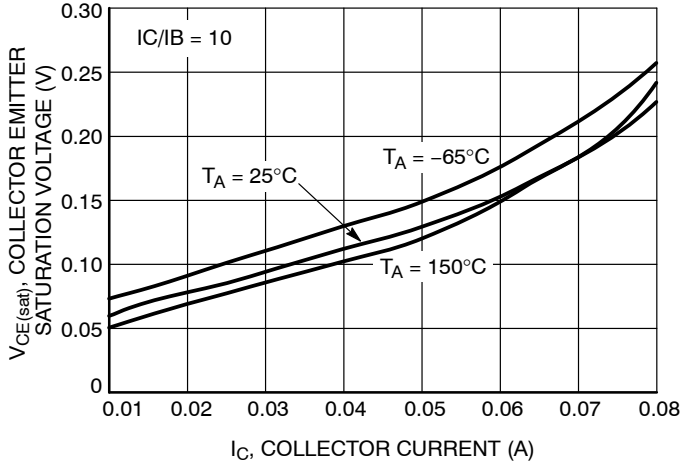

Figure 1.  $V_{CE(sat)}$  vs.  $I_C$

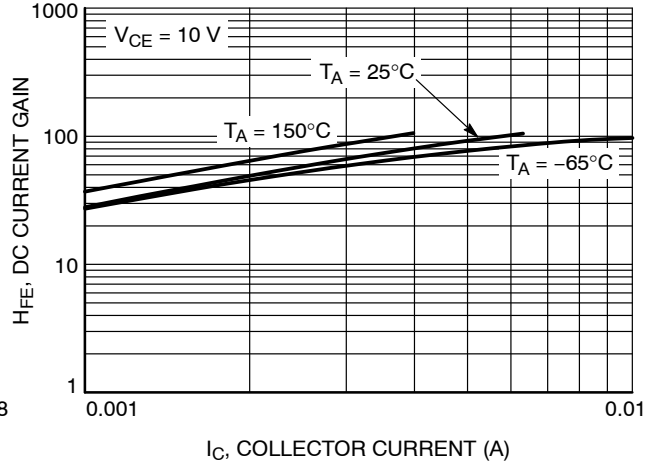

Figure 2. DC Current Gain

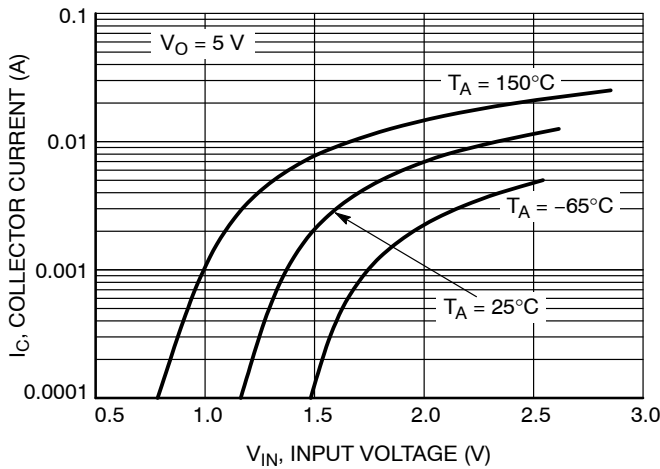

Figure 3. Output Current vs. Input Voltage

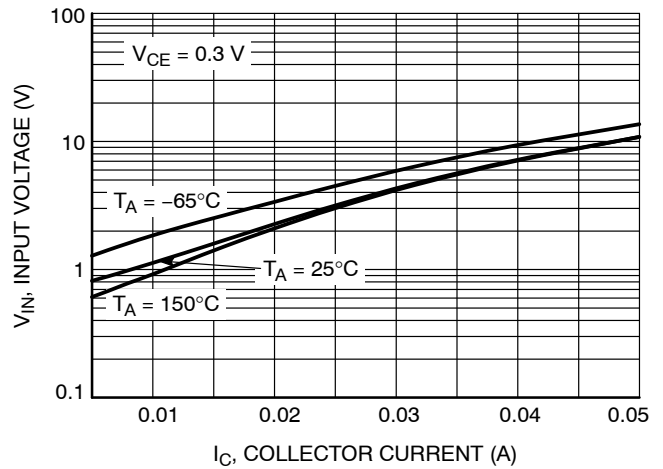

Figure 4. Input Voltage vs. Output Current

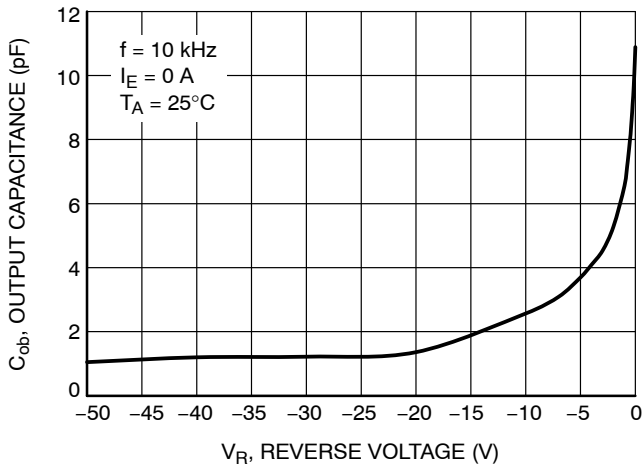

Figure 5. Output Capacitance

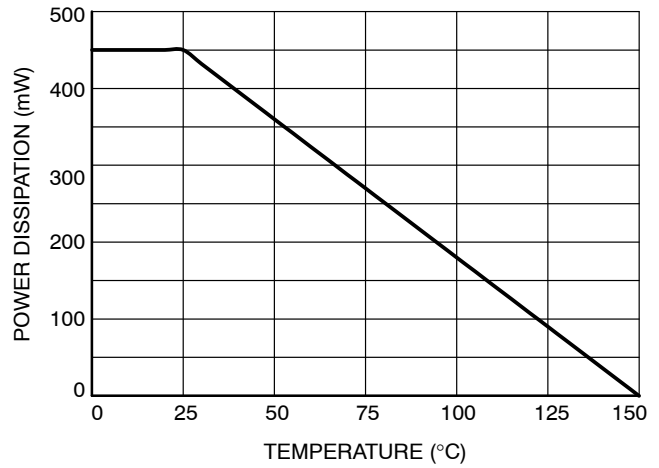

Figure 6. Derating Curve

# NSBAMXW Series

## TYPICAL CHARACTERISTICS

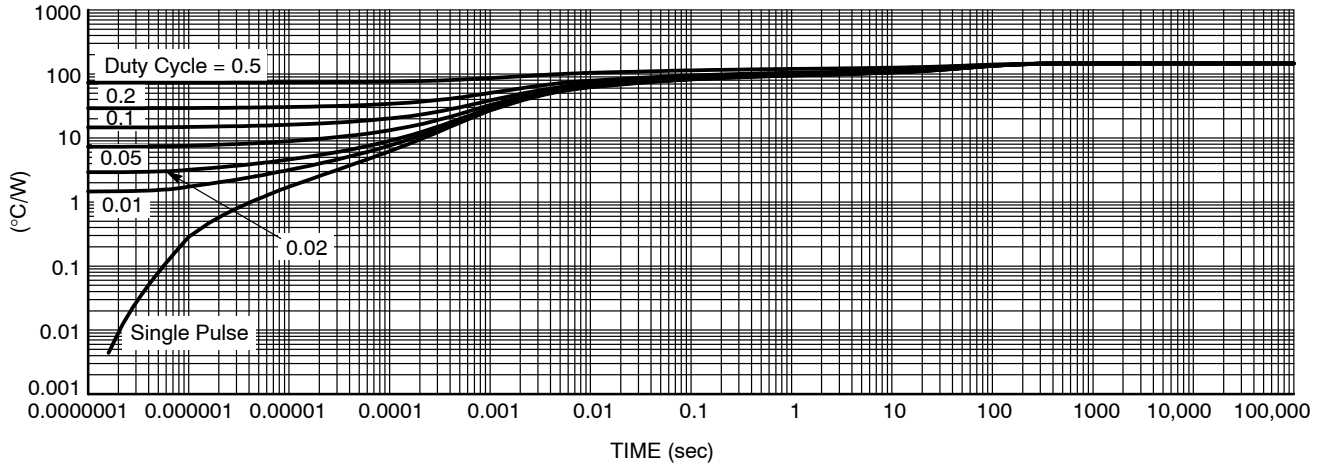
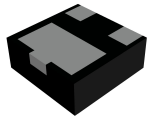
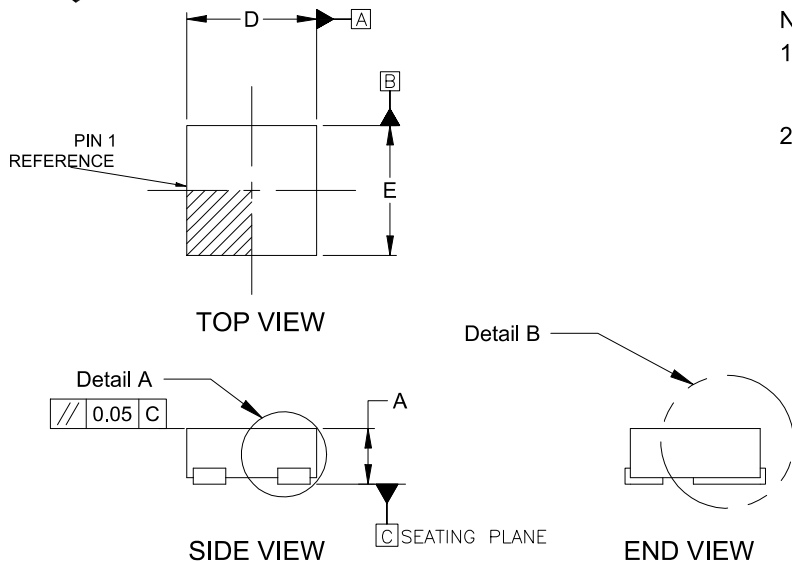

Figure 7. Transient Thermal Impedance from Junction-to-Ambient as a Function of Pulse Duration



**XDFNW3 1.00x1.00x0.38 0.65P**  
CASE 521AC  
ISSUE B

DATE 07 MAY 2024



NOTES:

1. DIMENSIONING AND TOLERANCING PER ASME Y14.5M, 2018.
2. CONTROLLING DIMENSION: MILLIMETERS

DIM	MILLIMETERS		
	MIN.	NOM.	MAX.
A	0.32	0.38	0.44
A1	0.00	---	0.04
A3	0.125 REF		
b	0.20	0.25	0.30
D	0.90	1.00	1.10
D1	0.00	---	0.04
D2	0.75	0.80	0.85
E	0.90	1.00	1.10
E2	0.40	0.45	0.50
e	0.65 BSC		
L	0.465	0.515	0.565
K	0.23 REF		

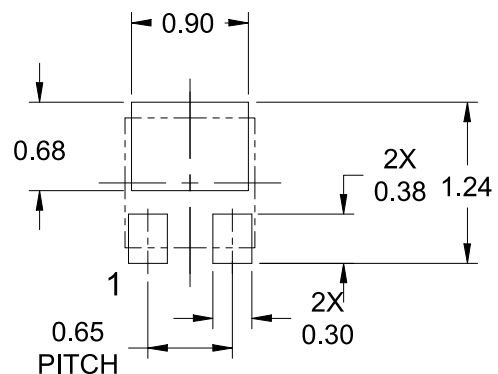
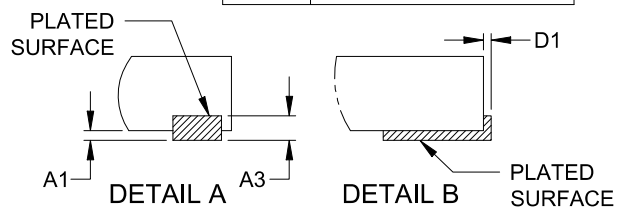
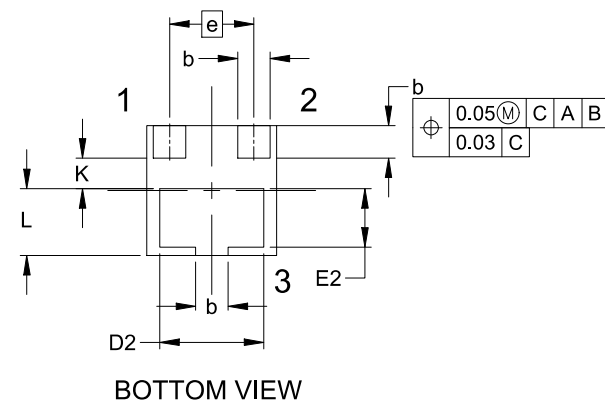

**GENERIC MARKING DIAGRAM\***

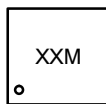

XX = Specific Device Code  
M = Month Code

\*This information is generic. Please refer to device data sheet for actual part marking. Pb-Free indicator, "G" or microdot "•", may or may not be present. Some products may not follow the Generic Marking.

**RECOMMENDED MOUNTING FOOTPRINT\***

\* For additional information on our Pb-Free strategy and soldering details, please download the ONSEMI Soldering and Mounting Techniques Reference Manual, S•LDERRM/D.

<b>DOCUMENT NUMBER:</b>	<b>98AON11341H</b>	Electronic versions are uncontrolled except when accessed directly from the Document Repository. Printed versions are uncontrolled except when stamped "CONTROLLED COPY" in red.
<b>DESCRIPTION:</b>	<b>XDFNW3 1.00x1.00x0.38 0.65P</b>	<b>PAGE 1 OF 1</b>

onsemi and ONSEMI are trademarks of Semiconductor Components Industries, LLC dba onsemi or its subsidiaries in the United States and/or other countries. onsemi reserves the right to make changes without further notice to any products herein. onsemi makes no warranty, representation or guarantee regarding the suitability of its products for any particular purpose, nor does onsemi assume any liability arising out of the application or use of any product or circuit, and specifically disclaims any and all liability, including without limitation special, consequential or incidental damages. onsemi does not convey any license under its patent rights nor the rights of others.

**onsemi**, **Onsemi**, and other names, marks, and brands are registered and/or common law trademarks of Semiconductor Components Industries, LLC dba "**onsemi**" or its affiliates and/or subsidiaries in the United States and/or other countries. **onsemi** owns the rights to a number of patents, trademarks, copyrights, trade secrets, and other intellectual property. A listing of **onsemi**'s product/patent coverage may be accessed at [www.onsemi.com/site/pdf/Patent-Marking.pdf](http://www.onsemi.com/site/pdf/Patent-Marking.pdf). **onsemi** reserves the right to make changes at any time to any products or information herein, without notice. The information herein is provided "as-is" and **onsemi** makes no warranty, representation or guarantee regarding the accuracy of the information, product features, availability, functionality, or suitability of its products for any particular purpose, nor does **onsemi** assume any liability arising out of the application or use of any product or circuit, and specifically disclaims any and all liability, including without limitation special, consequential or incidental damages. Buyer is responsible for its products and applications using **onsemi** products, including compliance with all laws, regulations and safety requirements or standards, regardless of any support or applications information provided by **onsemi**. "Typical" parameters which may be provided in **onsemi** data sheets and/or specifications can and do vary in different applications and actual performance may vary over time. All operating parameters, including "Typicals" must be validated for each customer application by customer's technical experts. **onsemi** does not convey any license under any of its intellectual property rights nor the rights of others. **onsemi** products are not designed, intended, or authorized for use as a critical component in life support systems or any FDA Class 3 medical devices or medical devices with a same or similar classification in a foreign jurisdiction or any devices intended for implantation in the human body. Should Buyer purchase or use **onsemi** products for any such unintended or unauthorized application, Buyer shall indemnify and hold **onsemi** and its officers, employees, subsidiaries, affiliates, and distributors harmless against all claims, costs, damages, and expenses, and reasonable attorney fees arising out of, directly or indirectly, any claim of personal injury or death associated with such unintended or unauthorized use, even if such claim alleges that **onsemi** was negligent regarding the design or manufacture of the part. **onsemi** is an Equal Opportunity/Affirmative Action Employer. This literature is subject to all applicable copyright laws and is not for resale in any manner.

---

## ADDITIONAL INFORMATION

### TECHNICAL PUBLICATIONS:

Technical Library: [www.onsemi.com/design/resources/technical-documentation](http://www.onsemi.com/design/resources/technical-documentation)  
onsemi Website: [www.onsemi.com](http://www.onsemi.com)

### ONLINE SUPPORT: [www.onsemi.com/support](http://www.onsemi.com/support)

For additional information, please contact your local Sales Representative at [www.onsemi.com/support/sales](http://www.onsemi.com/support/sales)